

Stretch Wrapper
CST205 AUTO



CYKLOP[®]
GLOBAL PACKAGING SOLUTIONS

STRAPPING
WRAPPING
CODING
TAPING

Stretch Wrapper CST205 AUTO

- The operator loads the pallet on the turntable and starts the wrapping cycle with remote control or touch panel.
- At the end of the cycle the machine cuts the film and the arm wipes the tail-end against the load.
- The film remains connected in the film gripper. Ready to receive the next pack.
- The complete cycle will be done in automatic mode.
- The operator unloads the pallet manually.

Easy change of all program parameters and settings with the new display. All functions can be manually operated such as film patterns and film tension. The chosen pre-stretch ratio stays constant, which guarantees a consistent low film consumption, load after load.

Standard machine specification and dimensions

Machine	Table diam	Ø1650 mm
	Speed	12rpm
	Capacity	10–25 pallets/hour(base on pallet height and turns to be wrapped)
	Start / stop	Frequency controlled
	Bottom/ top wraps	1–9
	Film carriage speed	Variable speed
	Pre-stretch ratio	250% and 200% manually, two–section variable (300% and 230% optional)
	Stretch wrapping programs	8 adjustable
	Controller	PLC
	Power	Supply
Loading		10 A
Pallet Goods	Max size (length x width)	1200 x 1000 mm
	Max. goods height incl. pallet:	2000 mm
	Permitted load weight	2000 Kg
Stretch Film	Core diameter	76 mm
	Outer diameter, max	250 mm
	Film width, max	500 mm
	Film thickness	9-35 my
Auto-function	Auto gripper for film end mounting	YES
	Constancy temperature heater for film end welding	YES
	Cutting wire for film cutting	YES
	Remote control	YES (3sets)

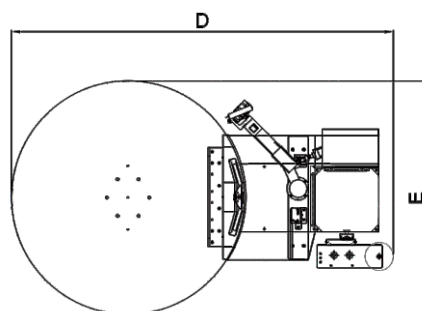
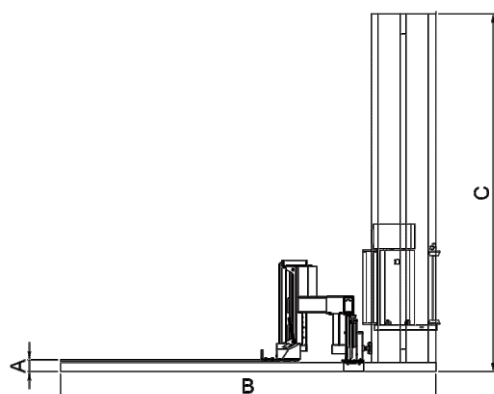

Dim(mm)	A	B	C	D	E
Standard	78	2600	2475	2704	1650