

NUT RUNNER

ELECTRIC NUT RUNNER GNR & GNRS Series



GNR Series
150~2100N·m 110~1550lbf·ft

GNRS Series
1600~10000N·m 1180~7380lbf·ft

Compact Body!
Light Weight!
High Power!

- Simple & Easy operation.
- Easily set your target torque, Easy switch Forward-reverse directions.
- Ergonomic design, lower sound level and double insulated protection motor.



NUT RUNNER (GNR Series)

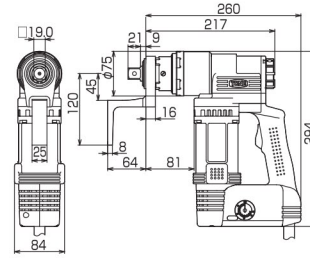
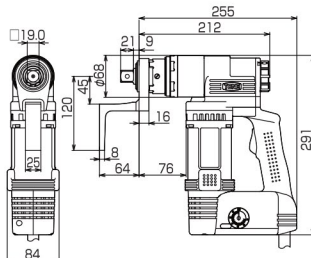
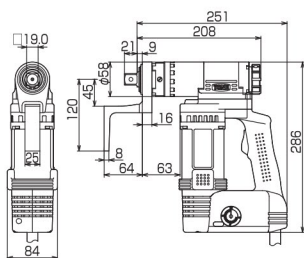

Models	GNR31E-CE	GNR32E-CE	GNR31E-UC	GNR51E-CE	GNR52E-CE	GNR51E-UC	GNR81E-CE	GNR82E-CE	GNR81E-UC
Frequency	50-60Hz			50-60Hz			50-60Hz		
Rated Voltage(Single Phase)	110-120V	220-230V	110-120V	110-120V	220-230V	110-120V	110-120V	220-230V	110-120V
Max.Current	10.5A	5.5A	10.5A	14.5A	7.5A	14.5A	14.5A	7.5A	14.5A
Rated Input Power	1150W(2s/3s)		1150W	1650W(2s/3s)		1650W	1650W(2s/3s)		1650W
Rated Max. Torque	300N·m		220lbf·ft	500N·m		370lbf·ft	800N·m		600lbf·ft
Repeated Accuracy	±5%			±5%			±5%		
Controllable Torque Range	150~300N·m		110~220lbf·ft	200~500N·m		150~370lbf·ft	350~800N·m		250~600lbf·ft
No-Load Speed	35min ⁻¹ (rpm)			29min ⁻¹ (rpm)			19min ⁻¹ (rpm)		
Noise & Vibration Level	Sound Pressure Level 86dB(A) Sound Power Level 97dB(A) Vibration Level Less than 2.5m/s ²			Sound Pressure Level 86dB(A) Sound Power Level 97dB(A) Vibration Level Less than 2.5m/s ²			Sound Pressure Level 86dB(A) Sound Power Level 97dB(A) Vibration Level Less than 2.5m/s ²		
Weight(Main Body)	4.5kg		9.9lbs	5.0kg		11.0lbs	5.4kg		11.9lbs
Protection Class	□(class II tool)			□(class II tool)			□(class II tool)		

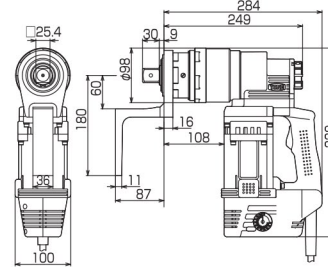
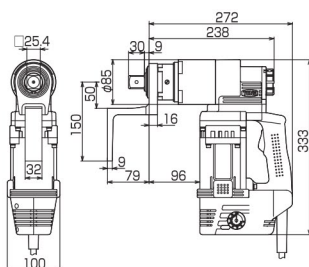
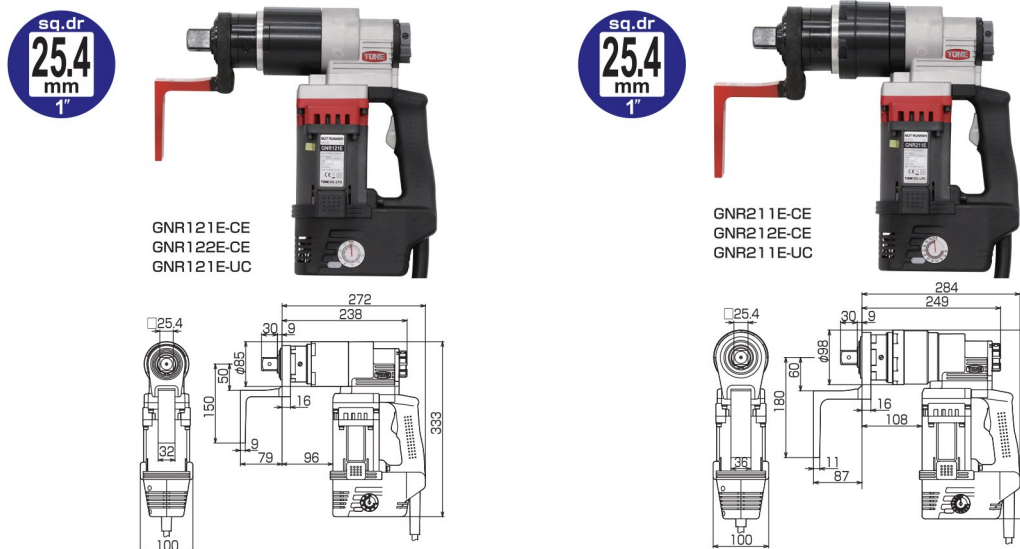

Models	GNR121E-CE	GNR122E-CE	GNR121E-UC	GNR211E-CE	GNR212E-CE	GNR211E-UC
Frequency	50-60Hz			50-60Hz		
Rated Voltage(Single Phase)	110-120V	220-230V	110-120V	110-120V	220-230V	110-120V
Max.Current	18A	9A	18A	18A	9A	18A
Rated Input Power	1900W(2s/3s)		1900W	1900W(2s/3s)		1900W
Rated Max. Torque	1200N·m		900lbf·ft	2100N·m		1550lbf·ft
Repeated Accuracy	±5%			±5%		
Controllable Torque Range	500~1200N·m		360~900lbf·ft	1000~2100N·m		750~1550lbf·ft
No-Load Speed	16min ⁻¹ (rpm)			8min ⁻¹ (rpm)		
Noise & Vibration Level	Sound Pressure Level 84dB(A) Sound Power Level 95dB(A) Vibration Level Less than 2.5m/s ²			Sound Pressure Level 84dB(A) Sound Power Level 95dB(A) Vibration Level Less than 2.5m/s ²		
Weight(Main Body)	7.3kg		16.1lbs	8.8kg		19.4lbs
Protection Class	□(class II tool)			□(class II tool)		

NUT RUNNER (GNRS Series)

sq.dr
25.4
mm
1"



GNRS401E-CE
GNRS402E-CE
GNRS401E-UC

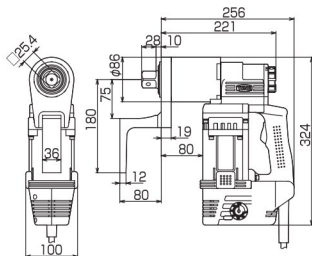

SPLINE
SOCKET
SPS60



GNRS601E-CE
GNRS602E-CE
GNRS601E-UC

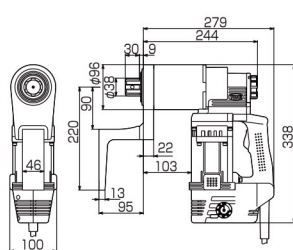

SPLINE
SOCKET
SPS100



GNRS1001E-CE
GNRS1002E-CE
GNRS1001E-UC

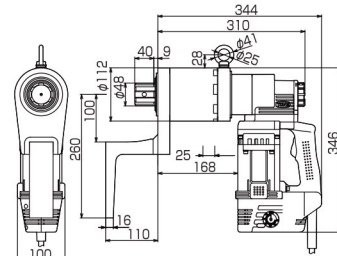

Models	GNRS401E-CE	GNRS402E-CE	GNRS401E-UC	GNRS601E-CE	GNRS602E-CE	GNRS601E-UC	GNRS1001E-CE	GNRS1002E-CE	GNRS1001E-UC
Frequency	50-60Hz			50-60Hz			50-60Hz		
Rated Voltage(Single Phase)	110-120V	220-230V	110-120V	110-120V	220-230V	110-120V	110-120V	220-230V	110-120V
Max.Current	18A	9A	18A	17A	8.5A	17A	17A	8.5A	17A
Rated Input Power	1900W(2s/3s)		1900W	1800W(2s/3s)		1800W	1800W(2s/3s)		1800W
Rated Max. Torque	4000N·m		2950lbf·ft	6000N·m		4430lbf·ft	10000N·m		7380lbf·ft
Repeated Accuracy	±5%			±5%			±5%		
Controllable Torque Range	1600~4000N·m		1180~2950lbf·ft	2400~6000N·m		1770~4430lbf·ft	4000~10000N·m		2950~7380lbf·ft
No-Load Speed	4min ⁻¹ (rpm)			2.5min ⁻¹ (rpm)			1.5min ⁻¹ (rpm)		
Noise & Vibration Level	Sound Pressure Level 84dB(A) Sound Power Level 95dB(A) Vibration Level Less than 2.5m/s ²			Sound Pressure Level 84dB(A) Sound Power Level 95dB(A) Vibration Level Less than 2.5m/s ²			Sound Pressure Level 84dB(A) Sound Power Level 95dB(A) Vibration Level Less than 2.5m/s ²		
Weight(Main Body)	9.0kg		19.8lbs	11.4kg		25.1lbs	16.3kg		35.9lbs
Protection Class	□(class II tool)			□(class II tool)			□(class II tool)		

SPLINE SOCKET

12pt

SPLINE
SOCKET
SPS60

FOR:GNRS601E-CE / GNRS602E-CE / GNRS601E-UC

SPLINE
SOCKET
SPS100

FOR:GNRS1001E-CE / GNRS1002E-CE / GNRS1001E-UC



SPS100W85

Models	Across Flat (mm)	Dimensions(mm)						Weight (kg)
		S	D ₁	D ₂	L ₁	L	d	
SPS60W50	50	72	57	26	89	40	1.2	
SPS60W55	55	80	60	29	89	40	1.5	
SPS60W60	60	85	60	31	89	40	1.5	
SPS60W65	65	90	62	34	89	45	1.7	
SPS60W70	70	97	62	36	89	48	1.7	
SPS60W75	75	103	62	38	90	50	1.8	
SPS60W80	80	108	62	42	94	54	1.9	
SPS60W85	85	113	62	45	99	58	2.1	
SPS60W90	90	119	62	48	102	62	2.3	
SPS60W95	95	124	62	51	107	66	2.4	
SPS60W100	100	130	62	54	110	70	2.5	
SPS60W105	105	136	62	58	114	75	2.5	

Models	Across Flat (mm)	Dimensions(mm)						Weight (g)
		S	D ₁	D ₂	L ₁	L	d	
SPS100W60	60	88	70	31	104	50	2.1	
SPS100W65	65	97	70	34	104	50	2.4	
SPS100W70	70	103	70	36	104	50	2.5	
SPS100W75	75	109	73	38	104	50	2.7	
SPS100W80	80	115	75	42	104	55	3.0	
SPS100W85	85	121	75	45	109	58	3.4	
SPS100W90	90	126	75	48	112	62	3.5	
SPS100W95	95	132	75	51	117	66	3.7	
SPS100W100	100	138	75	54	120	70	4.1	
SPS100W105	105	144	75	58	124	75	4.3	
SPS100W110	110	150	75	61	127	79	4.8	
SPS100W115	115	156	75	64	130	84	4.8	

